

TAV.
27
DATA - NOV. 07
Revisione - 03

POS.	CODICE MODELLO:				DESCRIZIONE	DESCRIPTION	DESCRIPTION	BESCHREIBUNG	Q.TY
	1100	1200	1250	1600					
1	1200540	1200540	1200540	1600540	Capotta lavapiatti	Manual dishwasher lid	Calotte lave-assiettes	Haube für Tellerwäscher	1
2	1202060	1202060	1202060	1602060	Colonna di lavaggio	Wash column	Colonne de lavage	Waschsäule	1
3	131	131	131	131	Dado Zn 8MA	Zn nut, 8MA	Ecrou ZN 8MA	Mutterschraube 8MA aus ZN	4
4	1201000	1201000	1201000	1601000	Maniglia inox	Stainless steel handle	Poignée inox	Griff aus Edelstahl	1
5	171	171	171	171	Rondella Zn M8	Zn washer, M8	Rondelle ZN M8	Unterlegscheibe M8 aus ZN	6
6	1202090	1202090	1202090	1202090	Buccole in pvc per molla	PVC bushes for spring	Douilles en PVC pour ressort	PVC-Auflage für Feder	2
7	251	251	251	251	Vite TE Zn M8x35	Zn TE screw, M8x35	Vis TE ZN M8x35	Schraube TE M8 aus ZN	2
8	1200521	1200521	1200521	1600521	Coperchio inox per schiena	Stainless steel cover for back	Couvercle inox pour panneau du fond	Deckel aus Edelstahl für Rückseite	1
9	280	280	280	280	Vite inox M4x10	Stainless steel screw,M4x10	Vis inox M4x10	Schraube aus Edelstahl M4x10	4
10	235	235	235	235	Vite TSPIC M6x30	TSPIC screw, M6x30	Vis TSPIC M6x30	Schraube TSPIC M8x30	6
11	1200520	1200520	1200520	1600520	Schiena inox	Stainless steel back	Panneau du fond inox	Rückseite aus Edelstahl	1
12	240	240	240	240	Vite TC inox M6x50	Stainless steel TC screw, M6x50	Vis TC inox M6x50	Schraube TC aus Edelstahl M6x50	4
13	1203010	1203010	1203010	1203010	Blocco in PVC per cerniera maniglia sup.	PVC block for upper handle hinge	Bloc en PVC pour charnière poignée sup.	PVC-Block für Scharnier vom oberen Griff	2
14	1203020	1203020	1203020	1203020	Blocco in PVC per cerniera maniglia inf.	PVC block for lower handle hinge	Bloc en PVC pour charnière poignée inf.	PVC-Block für Scharnier vom unteren Griff	2
15	1203030	1203030	1203030	1203030	Molla per capotta	Spring for manual lid	Ressort pour calotte	Feder für Haube	2
16	121	121	121	121	Dado 6MA Zn	Zn nut, 6MA	Ecrou 6MA ZN	Mutterschraube 6MA aus ZN	12
17	1202050	1202050	1202050	1602050	Pannello posteriore vasca	Rear tank panel	Panneau arrière cuve	Hintere Abdeckung Becken	1
18	1201045	1201045	1201045	1201045	Guida scorrimento capotta PVC	PVC manual lid sliding guide	Glissière calotte PVC	Laufschiene aus PVC für Haube	2
19	230	230	230	230	Vite TC inox M6x40	Stainless steel TC screw,M6x40	Vis TC inox M6x40	Schraube TC M6x40	12
20	1203060	1203060	1203060	1203060	Tirante gancio e occhiello M8	Hook and eye tension rod, M8	Tirant crochet et anneau M8	Zugstange Haken und Öse M8	2
21	1203065	1203065	1203065	1203065	Gancio M8 Zn	Zn hook, M8	Crochet M8 ZN	Haken M8 aus ZN	2
22	1202010	1202010	1202010	1602010	Struttura portante in acciaio inox	Stainless steel supporting structure	Structure portante en acier inoxydable	Tragende Struktur aus Edelstahl	1
23	1200551	1200551	1200551	1600551	Pannello laterale inferiore Dx	Lower right-hand side panel	Panneau latéral inférieur droit	Seitliche untere Abdeckung rechts	1
24	1000090	1000090	1000090	1000090	Piedino inox regolabile	Adjustable stainless steel foot	Pied inox réglable	Einstellbarer Fuß aus Edelstahl	4
25	1202000	1202000	1202000	1602000	Vasca completa lavapiatti	Complete dishwasher tank	Cuve complète lave-assiettes	Becken komplett von Tellerwäscher	1
26	1200550	1200550	1200550	1600550	Pannello anteriore	Front panel	Panneau avant	Vordere Abdeckung	1
27	1200552	1200552	1200552	1600552	Pannello laterale inf. Sx	Lower left-hand side panel	Panneau latéral inf. Gauche	Seitliche untere Abdeckung links	1
28	1200510	1200510	1200510	1600510	Cruscotto comandi	Control dashboard	Tableau des commandes	Bedienungsleiste	1
29	1201020	1201020	1201020	1601010	Portafiltri centrale	Central filter holder	Porte filtres central	Zentrale Filterhalterung	1
30	1201010	1201010	1201010	1601010	Filtro piano vasca	Flat filter for tank	Filtre plat cuve	Filter Ablage Becken	4
31	200	200	200	200	Vite TE inox M5x12	Stainless steel TE screw,M5x12	Vis TE inox M5x12	Schraube TE aus Edelstahl M5x12	6
32	150	150	150	150	Rondella piana inox M5	Flat stainless steel washer, M5	Rondelle plate inox M5	Flache Unterlegsch. aus Edelstahl M5	6
33	1201070	1201070	1201070	1601070	Guida laterale portacesto	Basket holding side guide	Guide latéral porte panier	Seitliche Schiene Korbbhalterung	2
34	110	110	110	110	Dado inox 5MA	Stainless steel nut, 5MA	Ecrou inox 5MA	Mutterschraube aus Edelstahl 5MA	6
35	120	120	120	120	Dado inox 6MA	Stainless steel nut, 6MA	Ecrou inox 6MA	Mutterschraube aus Edelstahl 6MA	4
36	1200570	1200570	1200570	160570	Supporto cesto	Basket support	Support panier	Korbbhalterung	1
37	250	250	250	250	Vite te inox M8x50	Stainless steel TE screw M8x50	Vis TE inox M8x50	Schraube TE aus Edelstahl M8x50	4
38	170	170	170	170	Rondella piana inox M8	Flat stainless steel washer M8	Rondelle plate inox M8	Flache Unterlegsch. aus Edelstahl M8	8
39	1202030	1202030	1202030	1202030	Tubo in ottone	Brass pipe	Tuyau en laiton	Messinglauch	4
40	1202040	1202040	1202040	1202040	Cilindro scorrimento maniglia PVC	PVC cylinder for sliding the handle	Cylindre de glissement poignée PVC	Laufzylinder Griff aus PVC	4
41	130	130	130	130	Dado inox 8MA	Stainless steel nut, 8MA	Ecrou inox 8MA	Mutterschraube aus Edelstahl 8MA	4

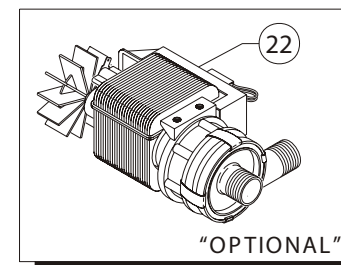
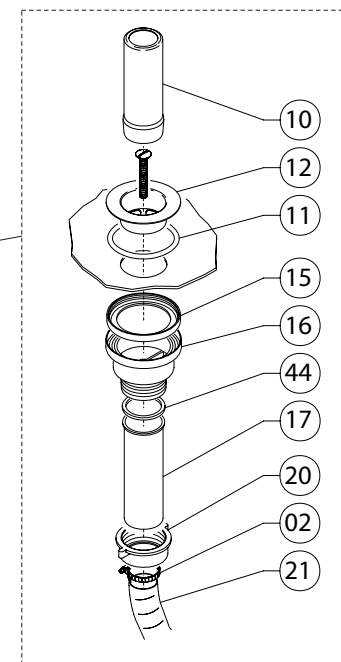
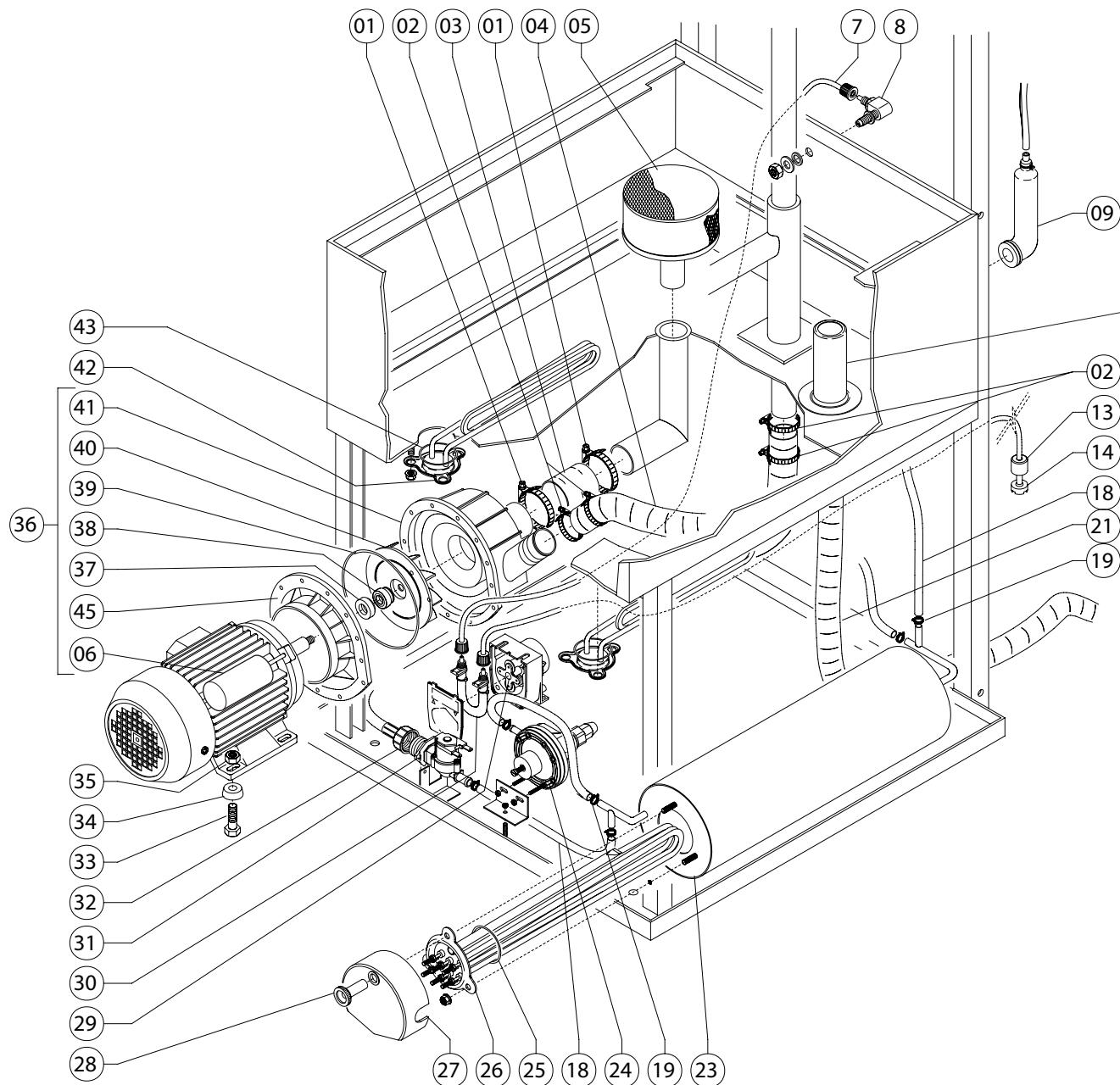

TAV.
28 DATA - NOV. 07
Revisione - 03

POS.	CODICE MODELLO: 1100	DESCRIZIONE	DESCRIPTION	DESCRIPTION	BESCHREIBUNG	Q.TY
1	550	Fascetta inox 50-70	Stainless steel band, 50-70	Collier inox 50-70	Schelle aus Edelstahl 50-70	2
2	560	Fascetta inox 59-63	Stainless steel band, 59-63	Collier inox 59-63	Schelle aus Edelstahl 59-63	2
3	1200700	Manicotto ingresso pompa	Pump entry rubber hose	Manchon entrée pompe	Muffe Pumpeneingang	1
4	1200705	Manicotto mandata	Delivery rubber hose	Manchon refoulement	Ausgangsmuffe	1
5	3260	Filtro inox	Stainless steel filter	Filtre inox	Filter aus Edelstahl	1
6	6515	Condensatore motore	Motor capacitor	Condensateur moteur	Kondensator vom Motor	1
7	1410	Tubetto 6 x 4 mm trasparente	Transparent tube, 6x4 mm	Petit tuyau 6x4 mm transparent	Kleiner transparen. Schlauch 6x4 mm	1
8	1211	Raccordo completo iniettore vasca	Complete joint for tank injector	Raccord complet injecteur cuve	Kompletter Anschluß	1
9	3280	Trappola d'aria	Air trap	Prise d'air	Lufffalle	1
10	1201091	Troppo pieno inox ø40	Stainless steel "too full" ø40	Trop-plein inox ø40	Überlauf aus Edelstahl ø40	1
11	1361	Guarnizione or interna piletta inox	OR gasket	Bague torique	O-Ring-Dichtung	1
12	1360	Piletta inox 1" 1/2	Discharge drain 1" 1/2	Siphon de vidange 1"1/2	Ablauf vom Abfluß 1"1/2	1
13	1215	Peso per tubetto aspirazione	Weight for intake tube	Poids pour petit tuyau aspiration	Gewicht für Ansaugschlauch	1
14	1218	Filtro per tubetto aspirazione	Filter for intake tube	Filtre pour petit tuyau aspiration	Filter für Ansaugschlauch	1
15	1363	Guarnizione esterna piana	Gasket for discharge drain	Joint pour siphon vidange	Dichtung für Ablauf vom Abfluß	1
16	1362	Raccordo polietilene	Joint	Raccord	Anschlub	1
17	1364	Codolo diritto scarico da 40 mm	Straight discharge shaft, 40 mm	Extr. droite tuyau de vidange de 40 mm	Gerades Endstück für Abfluß 40 mm	1
18	1380	Tubo gomma 10-19 90°C al metro	Rubber hose, 10-19 90°C per metre	Tuyau en caoutch .10-19 90°C au mètre	Gummischlauch 10-19 90°C, pro lfd. M	1
19	500	Fascetta inox 10-20	Stainless steel band, 10-20	Collier inox 10-20	Schelle aus Edelstahl 10-20	1
20	1367	Dado per codolo di scarico	Discharge shaft nut	Ecrou pour extrémité tuyau de vidange	Muttersch. für Endstück vom Abfluß	1
21	1320	Tubo di scarico ø32 mm	Discharge pipe, ø32 mm	Tuyau de vidange ø32 mm	Abflußschlauch ø32 mm	1
22	5200	Optional pompa di scarico 190 W	Optional discharge pump, 190W	Option pompe de vidange 190 W	Optional Pumpe für Abfluß 190 W	1
23	800420	Boiler inox	Stainless steel boiler	Chauffe-eau inox	Boiler aus Edelstahl	1
24	1200	Dosatore di brillantante	Rinse doser	Doseur de liquide rinçage	Dosierer für Klarspüler	1
25	103435	Guarnizione or per resistenza con flangia da 4500 W	OR heater gasket with flange, 4500W	Bague torique pour résistance avec bride de 4500 W	O-Ring-Dichtung für Heizschlange mit Flansch 4500 W	1
26	103430	Resistenza boiler 4500 W	Boiler heater, 4500W	Résistance chauffe-eau 4500 W	Heizschlange Boiler 4500 W	1
27	103460	Protezione resistenza boiler	Boiler heater protection	Protection résistance chauffe-eau	Schutz für Heizschlange Boiler	1
28	103470	Nottolino coperchio resistenza	Heater cover pawl	Cliquet couvercle résistance	Sperrzahn für Deckel von Heizsch.	1
29	1220	Dosatore di detergente elett. regolabile	Adjustable electric detergent doser	Doseur détergent électrique réglable	Elektr., einstell. Dosierer für Spülmittel	1
30	1212	Tubetto in santoprene	Santoprene tube	Petit tuyau en santoprène	Kleiner Schlauch aus Santopren	1
31	103370	Elettrovalvola	Solenoid valve	Electrovanne	Elektroventil	1
32	1305	Tubo di carico acqua da mt 2.0	Water entry pipe, 2.0 m	Tuyau de remplissage eau de 2 m	Wasseransaugschlauch, 2 m lang	1
33	251	Vite TE Zn M8x35	Zn TE screw, M8X35	Vis TE ZN M8X35	Schraube TE M8x35 aus ZN	1
34	180	Spessore motore	Motor shim	Cale moteur	Unterlage Motor	3
35	131	Dado Zn 8MA	Zn nut, 6MA	Ecrou 6MA ZN	Mutterschraube 6MA aus ZN	3
36	6500	Motore pompa HP 1,5	Pump motor, 1,5 HP	Moteur pompe HP 1,5	Motor pompe 1,5 PS	1
37	6013	Guarnizione tenuta ceramica	Ceramic sealing gasket	Joint d'étanchéité céramique	Keramikdichtung	1
38	6014	Guarnizione tenuta rotante	Rotary sealing gasket	Joint d'étanchéité rotatif	Dichtung Lauftrad	1
39	6514	Guarnizione or per chiocciola pompa	Pump volute OR gasket	Bague torique pour vis sans fin pompe	O-Ring-Dichtung für Spiralgeh. Pumpe	1
40	6511	Girante pompa lavaggio	Wash pump rotor	Roue pompe de lavage	Lauftrad Spülpumpe	1
41	6510	Chiocciola pompa	Pump volute	Vis sans fin pompe	Spiralgehäuse Pumpe	1
42	103450	Resistenza vasca 2500 w	Tank heater, 2500W	Résistance cuve 2500 W	Heizschlange Becken 2500 W	2
43	103415	Guarniz.OR per resistenza con flangia	OR heater gasket with flange	Bague torique résistance avec bride	O-Ring-Dichtung für Heizsch.mit Flansch	2
44	1366	Guarnizione codolo	Gasket	Joint	Dichtung	2
45	6513	Flangia motore pompa	flange wash pump	Bride moteur pompe	Flansch Pumpenmotor	1

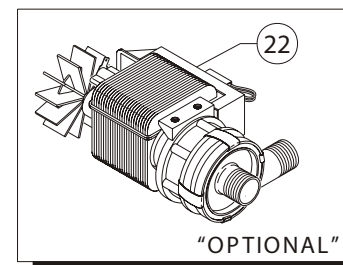
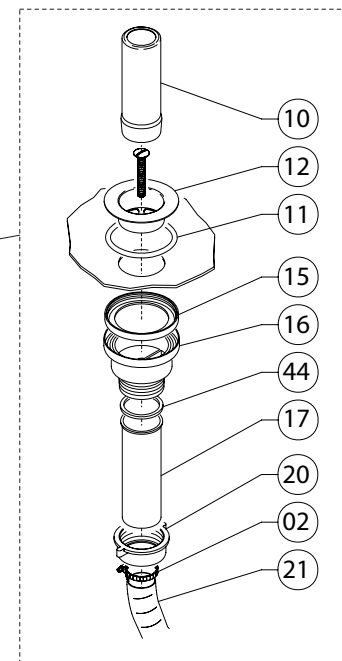
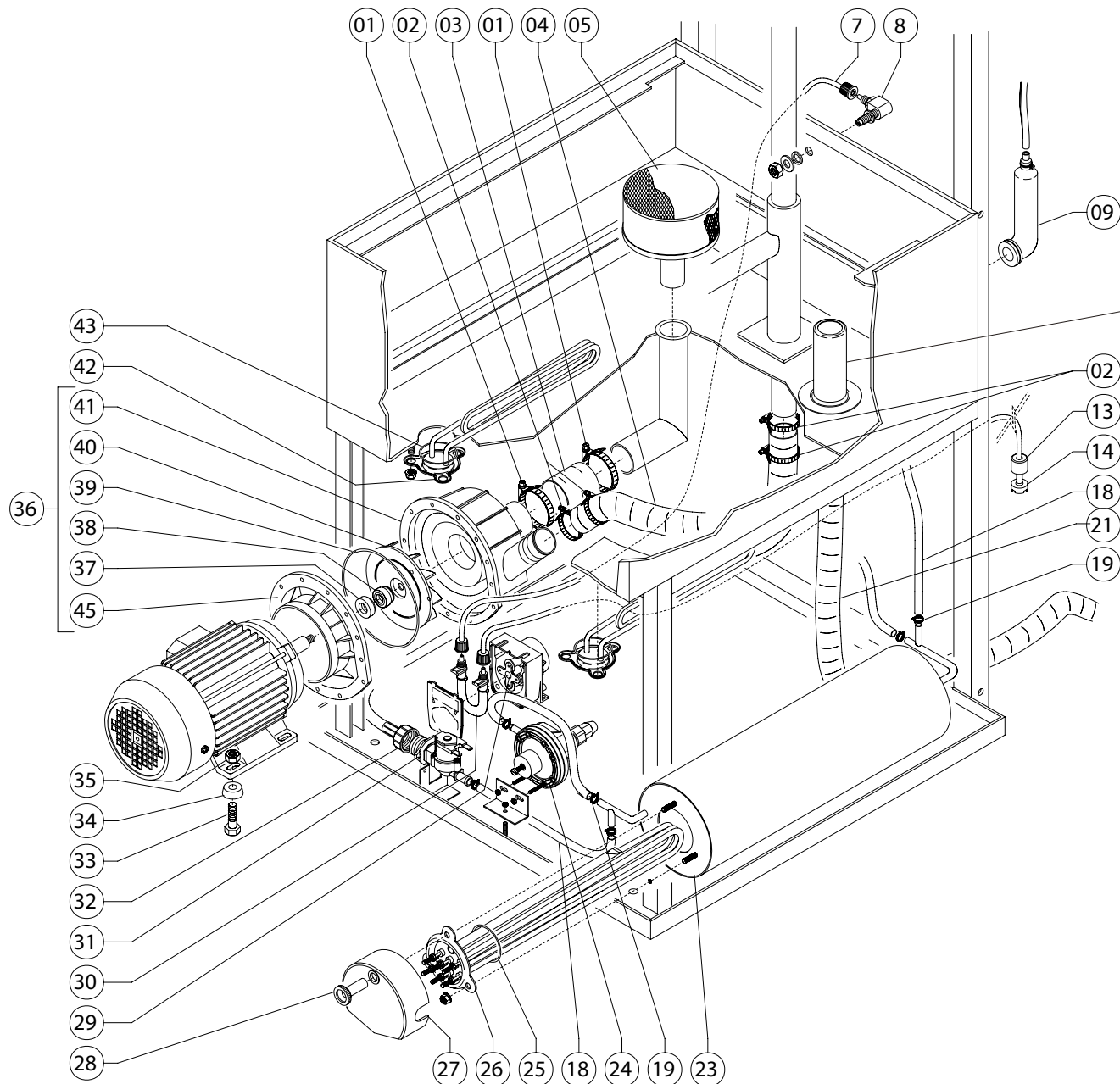

TAV.
29DATA - NOV. 07
Revisione - 03

POS.	CODICE MODELLO:			DESCRIZIONE	DESCRIPTION	DESCRIPTION	BESCHREIBUNG	Q.TY
	1200	1250	1350					
1	550	550	550	Fascetta inox 50-70	Stainless steel band, 50-70	Collier inox 50-70	Schelle aus Edelstahl 50-70	2
2	560	560	560	Fascetta inox 59-63	Stainless steel band, 59-63	Collier inox 59-63	Schelle aus Edelstahl 59-63	2
3	1200700	1200700	1200700	Manicotto ingresso pompa	Pump entry rubber hose	Manchon entrée pompe	Muffe Pumpeneingang	1
4	1200705	1200705	1200705	Manicotto mandata	Delivery rubber hose	Manchon refoulement	Ausgangsmuffe	1
5	3260	3260	3260	Filtro inox	Stainless steel filter	Filtre inox	Filter aus Edelstahl	1
7	1410	1410	1410	Tubetto 6 x 4 mm trasparente	Transparent tube, 6x4 mm	Petit tuyau 6x4 mm transparent	Kleiner transparen. Schlauch 6x4 mm	1
8	1211	1211	1211	Raccordo completo iniettore vasca	Complete joint for tank injector	Raccord complet injecteur cuve	Kompletter Anschluß	1
9	3280	3280	3280	Trappola d'aria	Air trap	Prise d'air	Luftfalle	1
10	1201091	1201091	1201091	Troppo pieno inox ø40	Stainless steel "too full" ø40	Trop-plein inox ø40	Überlauf aus Edelstahl ø40	1
11	1361	1361	1361	Guarnizione or interna piletta inox	OR gasket	Bague torique	O-Ring-Dichtung	1
12	1360	1360	1360	Piletta inox 1" 1/2	Discharge drain 1" 1/2	Siphon de vidange 1"1/2	Ablauf vom Abfluß 1"1/2	1
13	1215	1215	1215	Peso per tubetto aspirazione	Weight for intake tube	Poids pour petit tuyau aspiration	Gewicht für Ansaugschlauch	1
14	1218	1218	1218	Filtro per tubetto aspirazione	Filter for intake tube	Filtre pour petit tuyau aspiration	Filter für Ansaugschlauch	1
15	1363	1363	1363	Guarnizione esterna piana	Gasket for discharge drain	Joint pour siphon vidange	Dichtung für Ablauf vom Abfluß	1
16	1362	1362	1362	Raccordo polietilene	Joint	Raccord	Anschlub	1
17	1364	1364	1364	Codolo dritto scarico da 40 mm	Straight discharge shaft, 40 mm	Extr. droite tuyau de vidange de 40 mm	Gerades Endstück für Abfluß 40 mm	1
18	1380	1380	1380	Tubo gomma 10-19 90°C al metro	Rubber hose, 10-19 90°C per metre	Tuyau en caoutch .10-19 90°C au mètre	Gummischlauch 10-19 90°C, pro lfd. M	1
19	500	500	500	Fascetta inox 10-20	Stainless steel band, 10-20	Collier inox 10-20	Schelle aus Edelstahl 10-20	1
20	1367	1367	1367	Dado per codolo di scarico	Discharge shaft nut	Ecrou pour extrémité tuyau de vidange	Muttersch. für Endstück vom Abfluß	1
21	1320	1320	1320	Tubo di scarico ø32 mm	Discharge pipe, ø32 mm	Tuyau de vidange ø32 mm	Abflußschlauch ø32 mm	1
22	5200	5200	5200	Optional pompa di scarico 190 W	Optional discharge pump, 190W	Option pompe de vidange 190 W	Optional Pumpe für Abfluß 190 W	1
23	800420	800420	800420	Boiler inox	Stainless steel boiler	Chaufe-eau inox	Boiler aus Edelstahl	1
24	1200	1200	1200	Dosatore di brillantante	Rinse doser	Doseur de liquide rinçage	Dosierer für Klarspüler	1
25	103435	103435	103435	Guarnizione or per resistenza con flangia da 4500 W	OR heater gasket with flange, 4500W	Bague torique pour résistance avec bride de 4500 W	O-Ring-Dichtung für Heizschlange mit Flansch 4500 W	1
26	103432	-	-	Resistenza boiler 6000 W	Boiler heater, 6000W	Résistance chauffe-eau 6000 W	Heizschlange Boiler 6000 W	1
26	-	103440	-	Resistenza boiler 9000 W	Boiler heater, 9000W	Résistance chauffe-eau 9000 W	Heizschlange Boiler 9000 W	1
26	-	-	103430	Resistenza boiler 4500 W	Boiler heater, 4500W	Résistance chauffe-eau 4500 W	Heizschlange Boiler 4500 W	2
27	103460	103460	103460	Protezione resistenza boiler	Boiler heater protection	Protection résistance chauffe-eau	Schutz für Heizschlange Boiler	1
28	103470	103470	103470	Nottolino coperchio resistenza	Heater cover pawl	Cliquet couvercle résistance	Sperrzahn für Deckel von Heizsch.	1
29	1220	1220	1220	Dosatore di detergente elett. regolabile	Adjustable electric detergent doser	Doseur détergent électrique réglable	Elektr., einstell. Dosierer für Spülmittel	1
30	1212	1212	1212	Tubetto in santoprene	Santoprene tube	Petit tuyau en santoprène	Kleiner Schlauch aus Santopren	1
31	103370	103370	103370	Elettrovalvola	Solenoid valve	Electrovanne	Elektroventil	1
32	1305	1305	1305	Tubo di carico acqua da mt 2.0	Water entry pipe, 2.0 m	Tuyau de remplissage eau de 2 m	Wasseransaugschlauch, 2 m lang	1
33	251	251	251	Vite TE Zn M8x35	Zn TE screw, M8X35	Vis TE ZN M8X35	Schraube TE M8x35 aus ZN	1
34	180	180	180	Spessore motore	Motor shim	Cale moteur	Unterlage Motor	3
35	131	131	131	Dado Zn 8MA	Zn nut, 6MA	Ecrou 6MA ZN	Mutterschraube 6MA aus ZN	3
36	6600	6600	6600	Motore pompa HP 2,7	Pump motor, 2,7 HP	Moteur pompe HP 2,7	Motorpumpe 2,7 PS	1
37	6013	6013	6013	Guarnizione tenuta ceramica	Ceramic sealing gasket	Joint d'étanchéité céramique	Keramikdichtung	1
38	6014	6014	6014	Guarnizione tenuta rotante	Rotary sealing gasket	Joint d'étanchéité rotatif	Dichtung Laufrad	1
39	6614	6614	6614	Guarnizione or per chiocciola pompa	Pump volute OR gasket	Bague torique pour vis sans fin pompe	O-Ring-Dichtung für Spiralgeh. Pumpe	1
40	6611	6611	6611	Girante pompa lavaggio	Wash pump rotor	Roue pompe de lavage	Laufrad Spülpumpe	1
41	6610	6610	6610	Chiocciola pompa	Pump volute	Vis sans fin pompe	Spiralgehäuse Pumpe	1
42	103450	103450	103450	Resistenza vasca 2500 w	Tank heater, 2500W	Résistance cuve 2500 W	Heizschlange Becken 2500 W	2
43	103415	103415	103415	Guarniz.OR per resistenza con flangia	OR heater gasket with flange	Bague torique résistance avec bride	O-Ring-Dichtung für Heizsch.mit Flansch	2
44	1366	1366	1366	Guarnizione codolo	Gasket	Joint	Dichtung	2
45	6613	6613	6613	Flangia motore pompa HP 2,7	flange wash pump 2,7 HP	Bride moteur pompe	Flansch Pumpenmotor	1

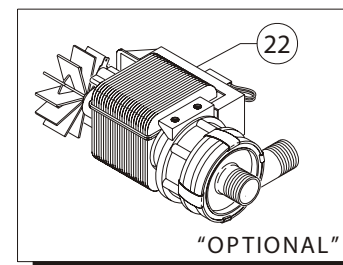
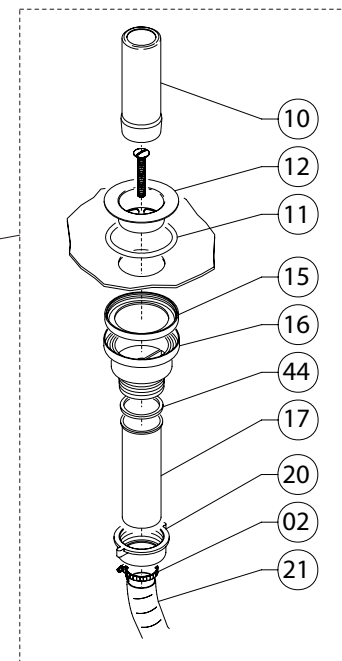
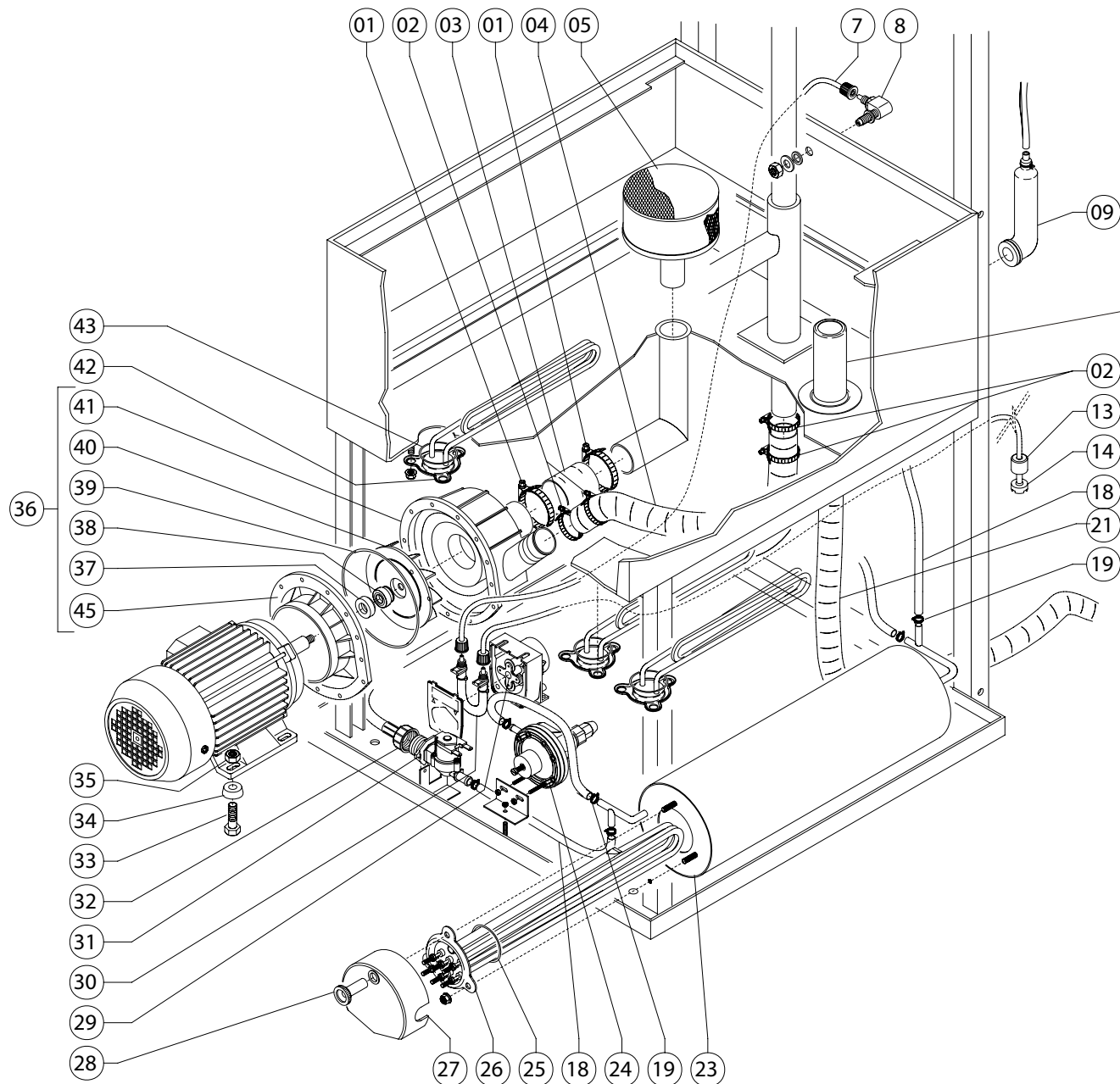

TAV. DATA - NOV. 07
30 Revisione - 03

POS.	CODICE MODELLO:		DESCRIZIONE	DESCRIPTION	DESCRIPTION	BESCHREIBUNG	Q.TY
	1600	1650					
1	550	550	Fascetta inox 50-70	Stainless steel band, 50-70	Collier inox 50-70	Schelle aus Edelstahl 50-70	2
2	560	560	Fascetta inox 59-63	Stainless steel band, 59-63	Collier inox 59-63	Schelle aus Edelstahl 59-63	2
3	1600700	1600700	Manicotto ingresso pompa	Pump entry rubber hose	Manchon entrée pompe	Muffe Pumpeneingang	1
4	1600705	1600705	Manicotto mandata	Delivery rubber hose	Manchon refoulement	Ausgangsmuffe	1
5	3260	3260	Filtro inox	Stainless steel filter	Filtre inox	Filter aus Edelstahl	1
7	1410	1410	Tubetto 6 x 4 mm trasparente	Transparent tube, 6x4 mm	Petit tuyau 6x4 mm transparent	Kleiner transparen. Schlauch 6x4 mm	1
8	1211	1211	Raccordo completo iniettore vasca	Complete joint for tank injector	Raccord complet injecteur cuve	Kompletter Anschluß	1
9	3280	3280	Trappola d'aria	Air trap	Prise d'air	Luftfalle	1
10	1201091	1201091	Troppo pieno inox ø40	Stainless steel "too full" ø40	Trop-plein inox ø40	Überlauf aus Edelstahl ø40	1
11	1361	1361	Guarnizione or interna piletta inox	OR gasket	Bague torique	O-Ring-Dichtung	1
12	1360	1360	Piletta inox 1" 1/2	Discharge drain 1" 1/2	Siphon de vidange 1"1/2	Ablauf vom Abfluß 1"1/2	1
13	1215	1215	Peso per tubetto aspirazione	Weight for intake tube	Poids pour petit tuyau aspiration	Gewicht für Ansaugschlauch	1
14	1218	1218	Filtro per tubetto aspirazione	Filter for intake tube	Filtre pour petit tuyau aspiration	Filter für Ansaugschlauch	1
15	1363	1363	Guarnizione esterna piana	Gasket for discharge drain	Joint pour siphon vidange	Dichtung für Ablauf vom Abfluß	1
16	1362	1362	Raccordo polietilene	Joint	Raccord	Anschluß	1
17	1364	1364	Codolo diritto scarico da 40 mm	Straight discharge shaft, 40 mm	Extr. droite tuyau de vidange de 40 mm	Gerades Endstück für Abfluß 40 mm	1
18	1380	1380	Tubo gomma 10-19 90°C al metro	Rubber hose, 10-19 90°C per metre	Tuyau en caoutch .10-19 90°C au mètre	Gummischlauch 10-19 90°C, pro lfd. M	1
19	500	500	Fascetta inox 10-20	Stainless steel band, 10-20	Collier inox 10-20	Schelle aus Edelstahl 10-20	1
20	1367	1367	Dado per codolo di scarico	Discharge shaft nut	Ecrou pour extrémité tuyau de vidange	Muttersch. für Endstück vom Abfluß	1
21	1320	1320	Tubo di scarico ø32 mm	Discharge pipe, ø32 mm	Tuyau de vidange ø32 mm	Abflußschlauch ø32 mm	1
22	5200	5200	Optional pompa di scarico 190 W	Optional discharge pump, 190W	Option pompe de vidange 190 W	Optional Pumpe für Abfluß 190 W	1
23	950420	950420	Boiler inox	Stainless steel boiler	Chauffe-eau inox	Boiler aus Edelstahl	1
24	1200	1200	Dosatore di brillantante	Rinse doser	Doseur de liquide rinçage	Dosierer für Klarspüler	1
25	103435	103435	Guarnizione or per resistenza con flangia da 4500 W	OR heater gasket with flange, 4500W	Bague torique pour résistance avec bride de 4500 W	O-Ring-Dichtung für Heizschlange mit Flansch 4500 W	1
26	103440	-	Resistenza boiler 9000 W	Boiler heater, 9000W	Résistance chauffe-eau 9000 W	Heizschlange Boiler 9000 W	1
26	-	103430	Resistenza boiler 4500 W	Boiler heater, 4500W	Résistance chauffe-eau 4500 W	Heizschlange Boiler 4500 W	2
27	103460	103460	Protezione resistenza boiler	Boiler heater protection	Protection résistance chauffe-eau	Schutz für Heizschlange Boiler	1
28	103470	103470	Nottolino coperchio resistenza	Heater cover pawl	Cliquet couvercle résistance	Sperrzahn für Deckel von Heizsch.	1
29	1220	1220	Dosatore di detergente elett. regolabile	Adjustable electric detergent doser	Doseur détergent électrique réglable	Elektr., einstell. Dosierer für Spülmittel	1
30	1212	1212	Tubetto in santoprene	Santoprene tube	Petit tuyau en santoprène	Kleiner Schlauch aus Santopren	1
31	103370	103370	Elettrovalvola	Solenoid valve	Electrovanne	Elektroventil	1
32	1305	1305	Tubo di carico acqua da mt 2.0	Water entry pipe, 2.0 m	Tuyau de remplissage eau de 2 m	Wasseransaugschlauch, 2 m lang	1
33	251	251	Vite TE Zn M8x35	Zn TE screw, M8X35	Vis TE ZN M8X35	Schraube TE M8x35 aus ZN	1
34	180	180	Spessore motore	Motor shim	Cale moteur	Unterlage Motor	3
35	131	131	Dado Zn 8MA	Zn nut, 6MA	Ecrou 6MA ZN	Mutterschraube 6MA aus ZN	3
36	6700	6700	Motore pompa HP 3,0	Pump motor, 3,0 HP	Moteur pompe HP 3,0	Motor pompe 3,0 PS	1
37	6013	6013	Guarnizione tenuta ceramica	Ceramic sealing gasket	Joint d'étanchéité céramique	Keramikdichtung	1
38	6014	6014	Guarnizione tenuta rotante	Rotary sealing gasket	Joint d'étanchéité rotatif	Dichtung Laufrad	1
39	6714	6714	Guarnizione or per chiocciola pompa	Pump volute OR gasket	Bague torique pour vis sans fin pompe	O-Ring-Dichtung für Spiralgeh. Pumpe	1
40	6711	6711	Girante pompa lavaggio	Wash pump rotor	Roue pompe de lavage	Laufrad Spülpumpe	1
41	6710	6710	Chiocciola pompa	Pump volute	Vis sans fin pompe	Spiralgehäuse Pumpe	1
42	103450	103450	Resistenza vasca 2500 w	Tank heater, 2500W	Résistance cuve 2500 W	Heizschlange Becken 2500 W	3
43	103415	103415	Guarniz.OR per resistenza con flangia	OR heater gasket with flange	Bague torique résistance avec bride	O-Ring-Dichtung für Heizsch.mit Flansch	2
44	1366	1366	Guarnizione codolo	Gasket	Joint	Dichtung	2
45	6713	6713	Flangia motore pompa HP 3,0	flange wash pump 3,0 HP	Bride moteur pompe	Flansch Pumpenmotor	1

KORAL 1100

TAV.31

GIRANTE

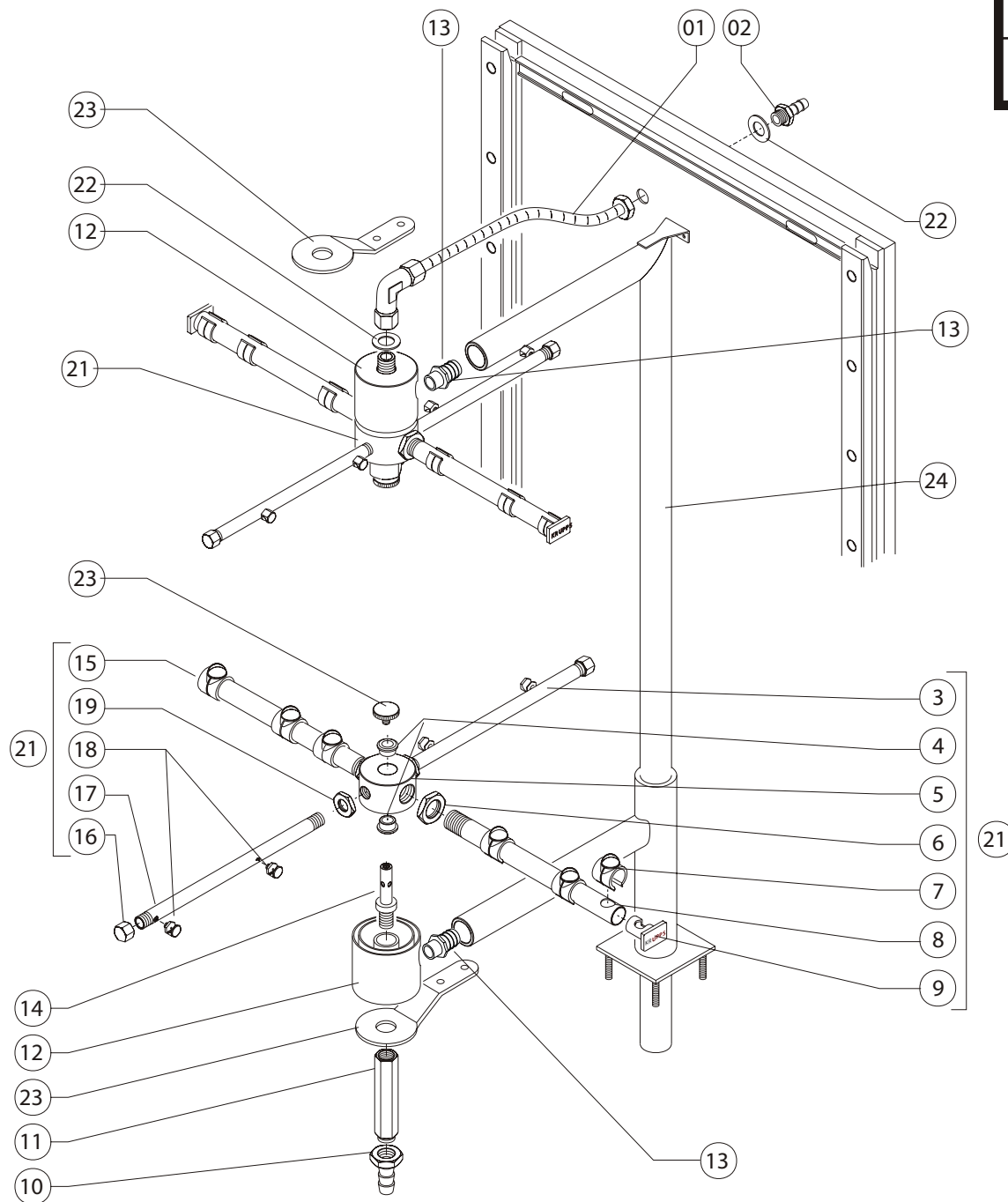

KORAL 1200

TAV.32

GIRANTE

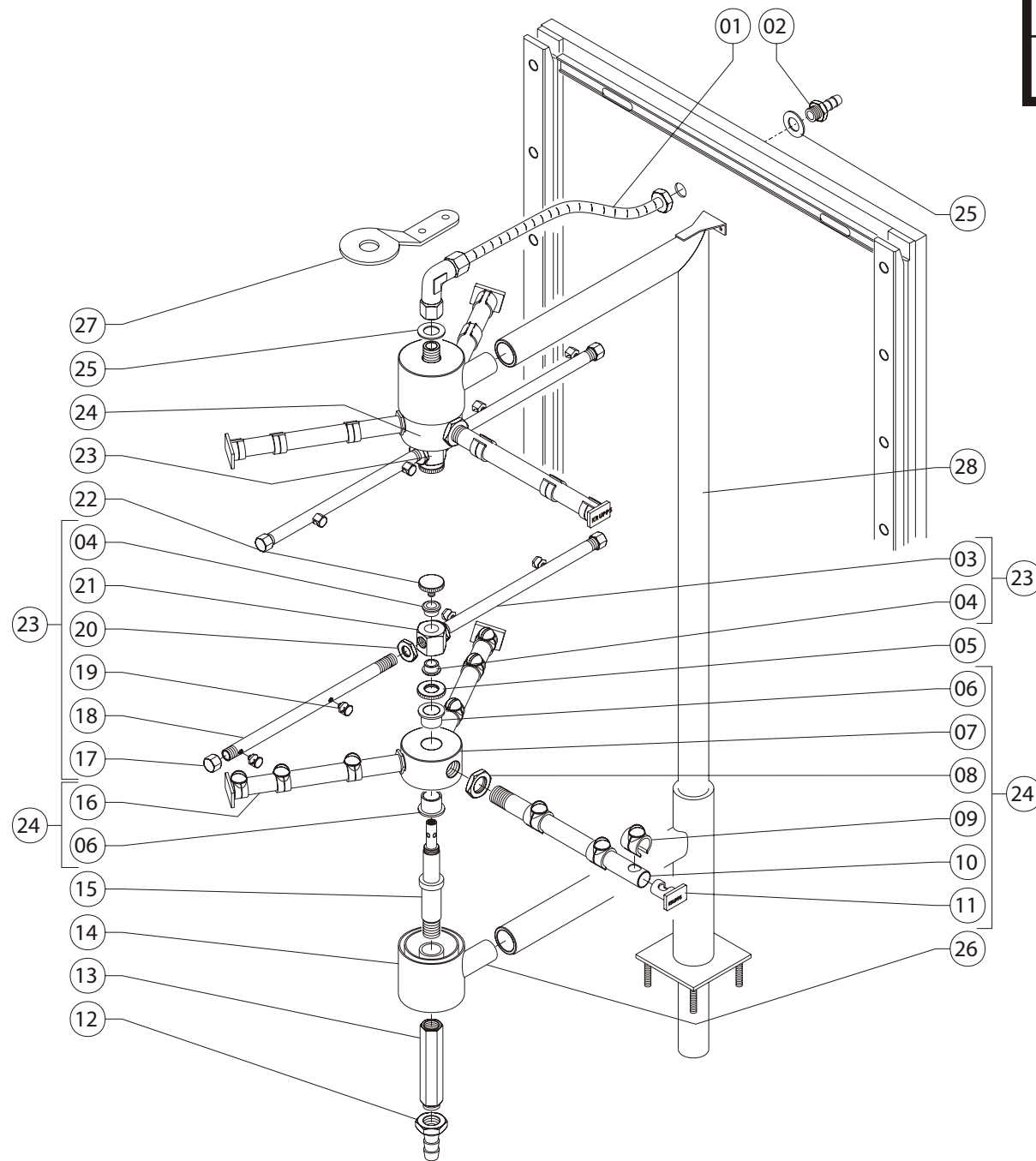

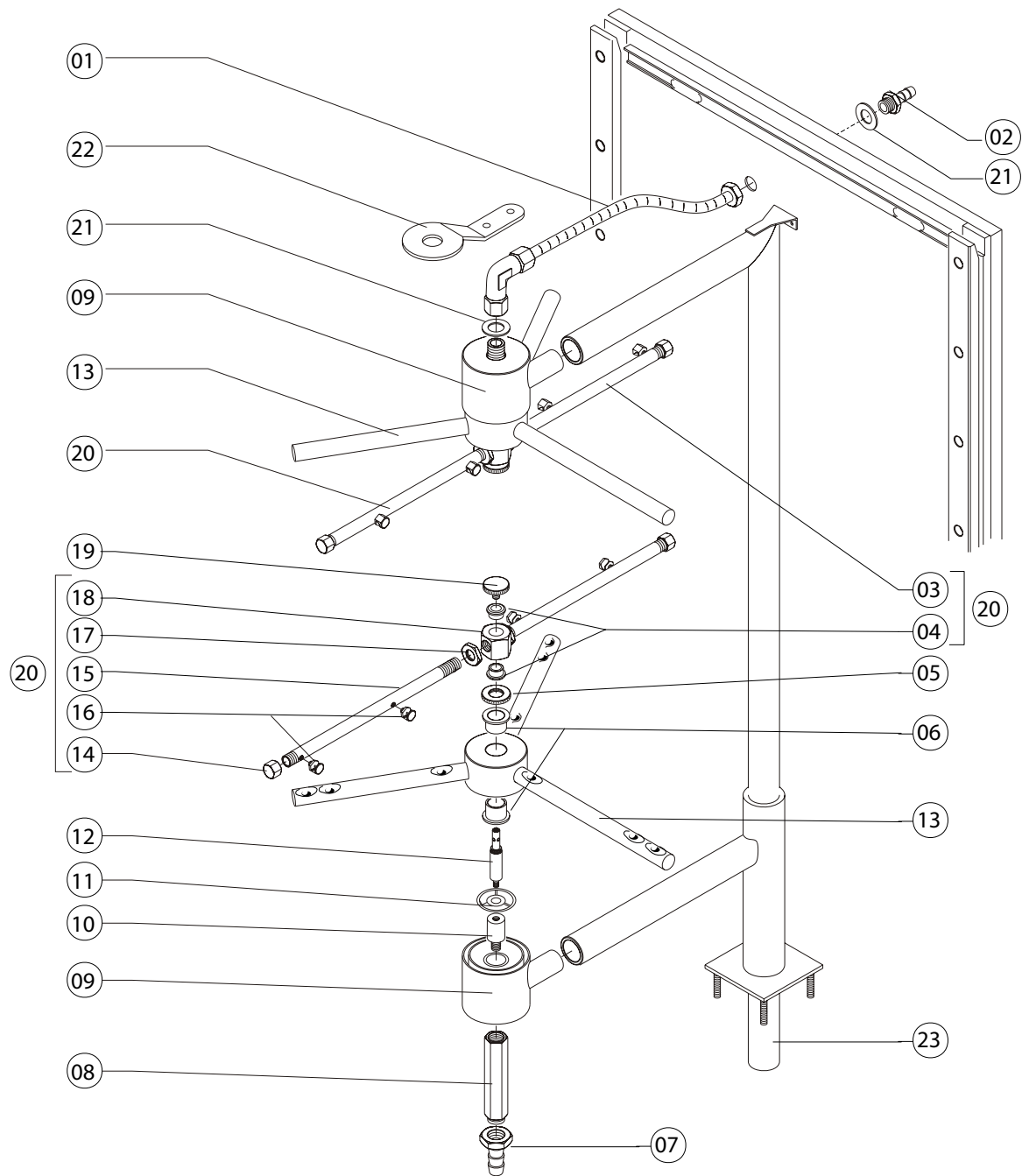

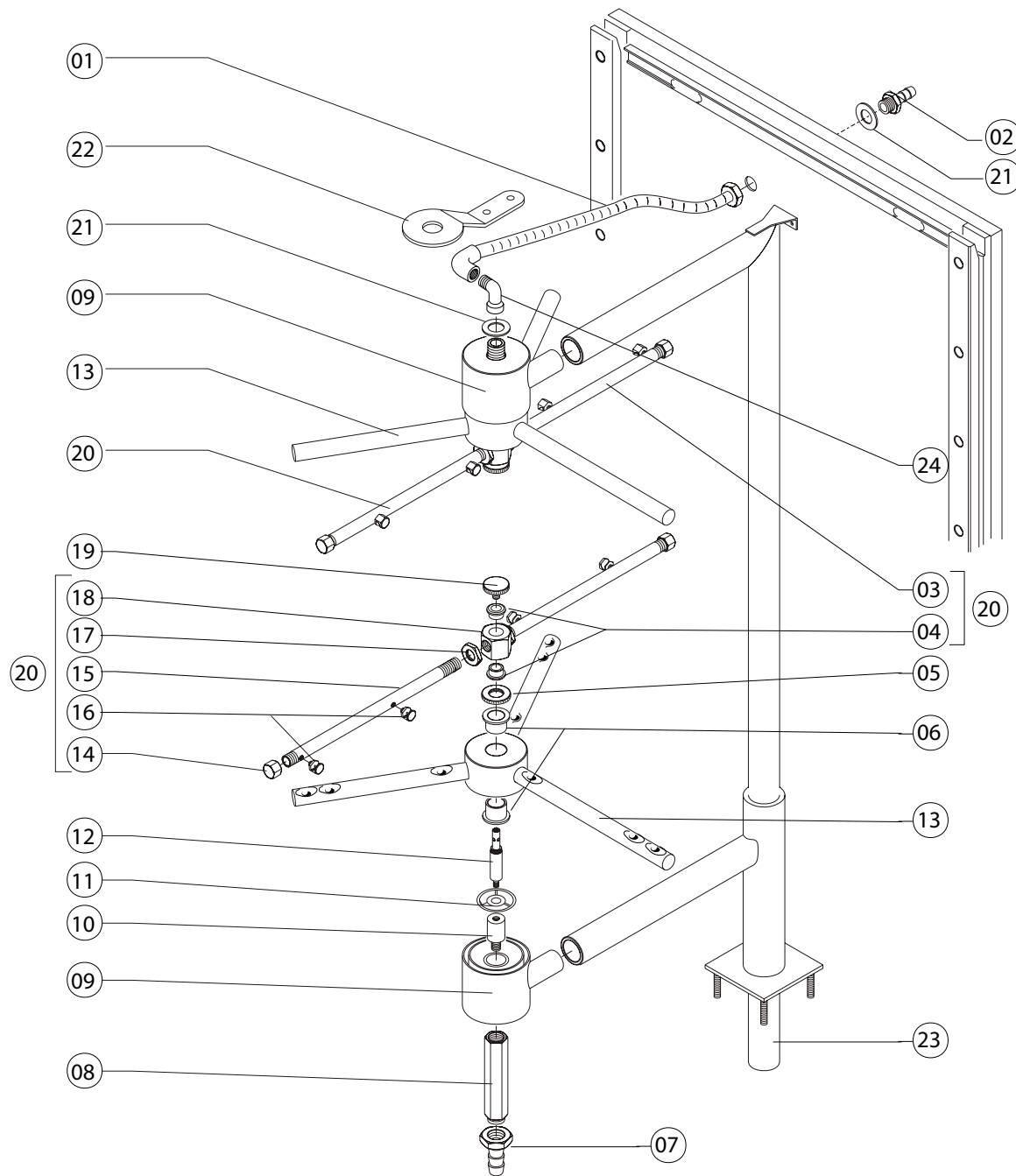

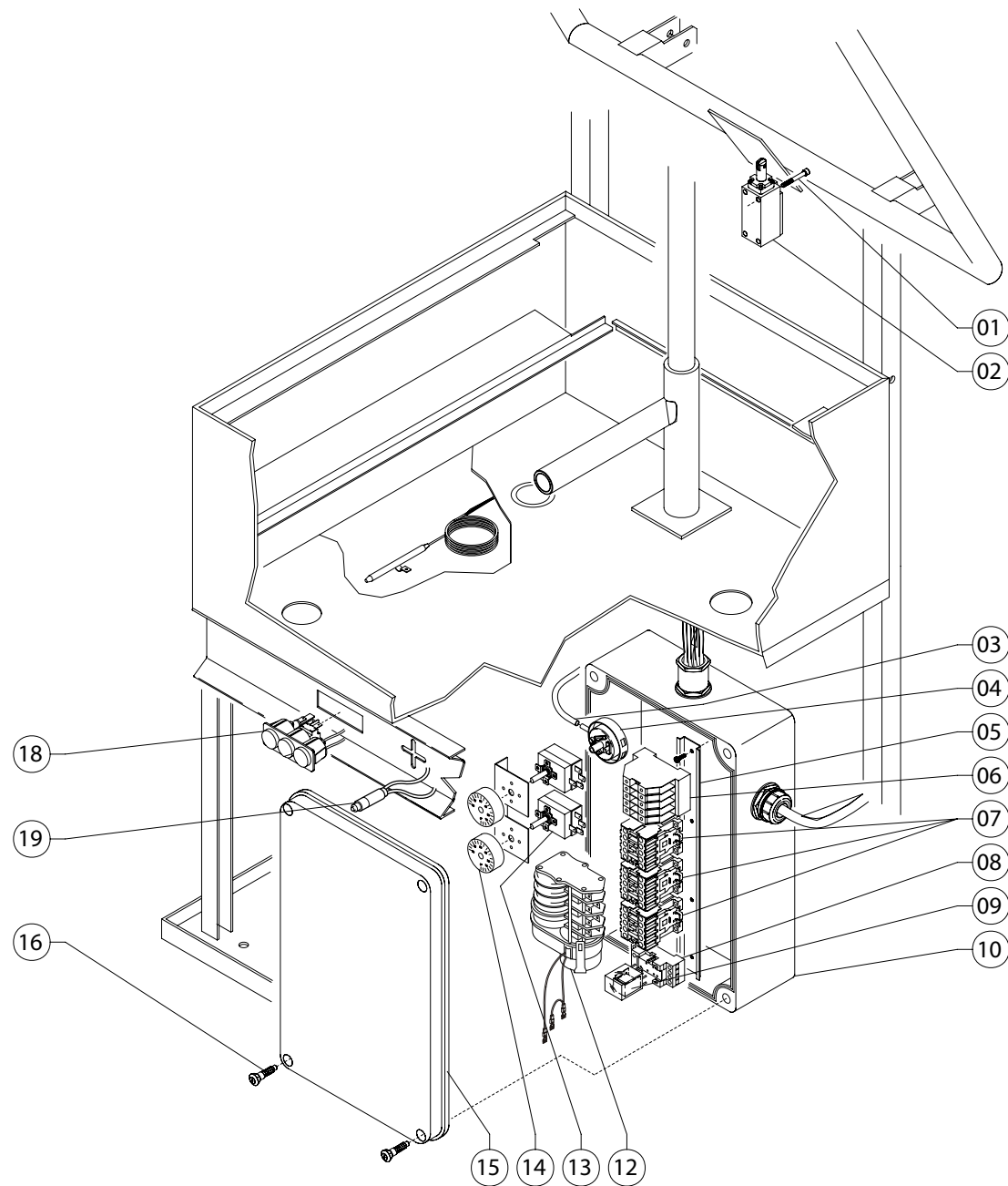

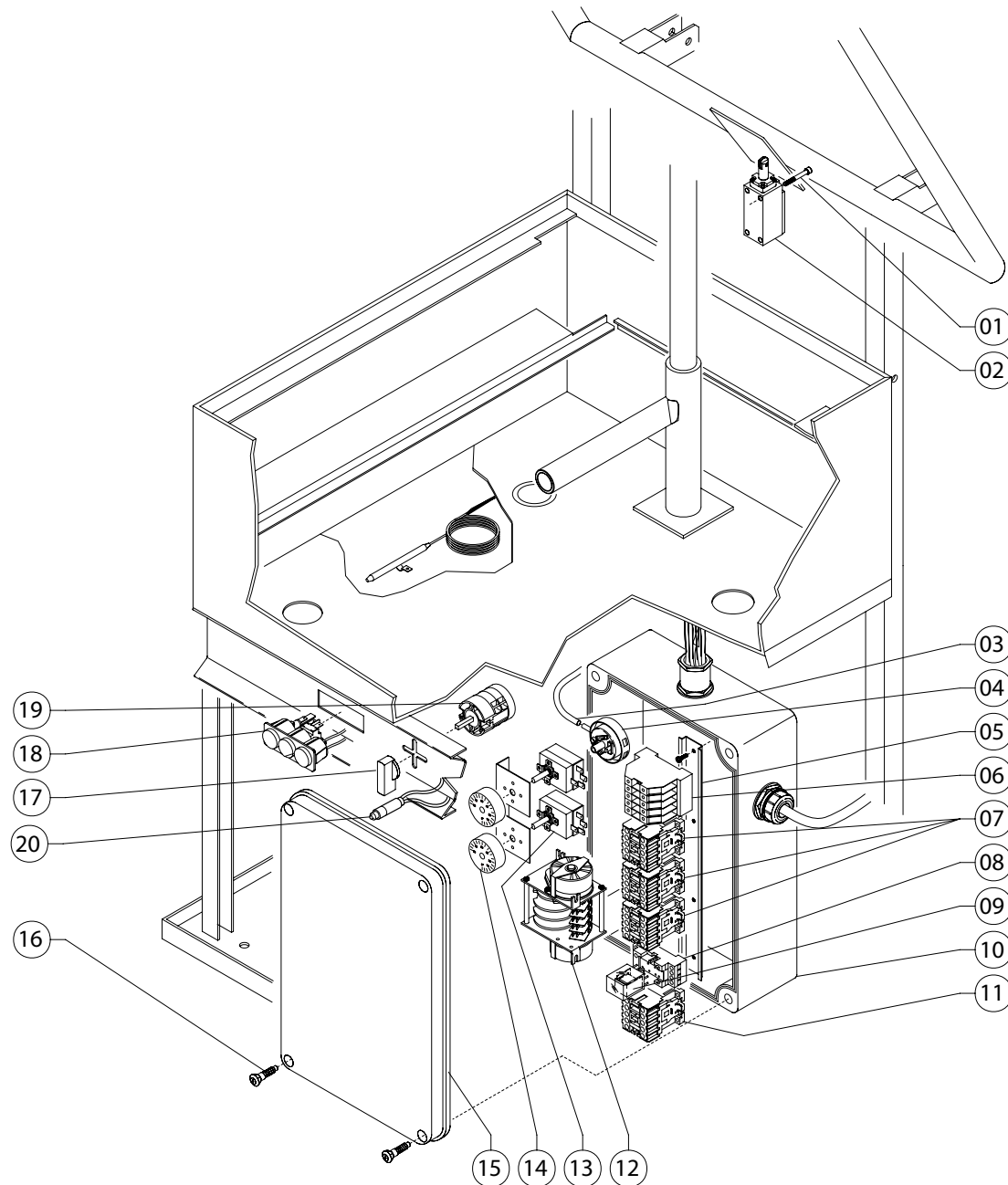

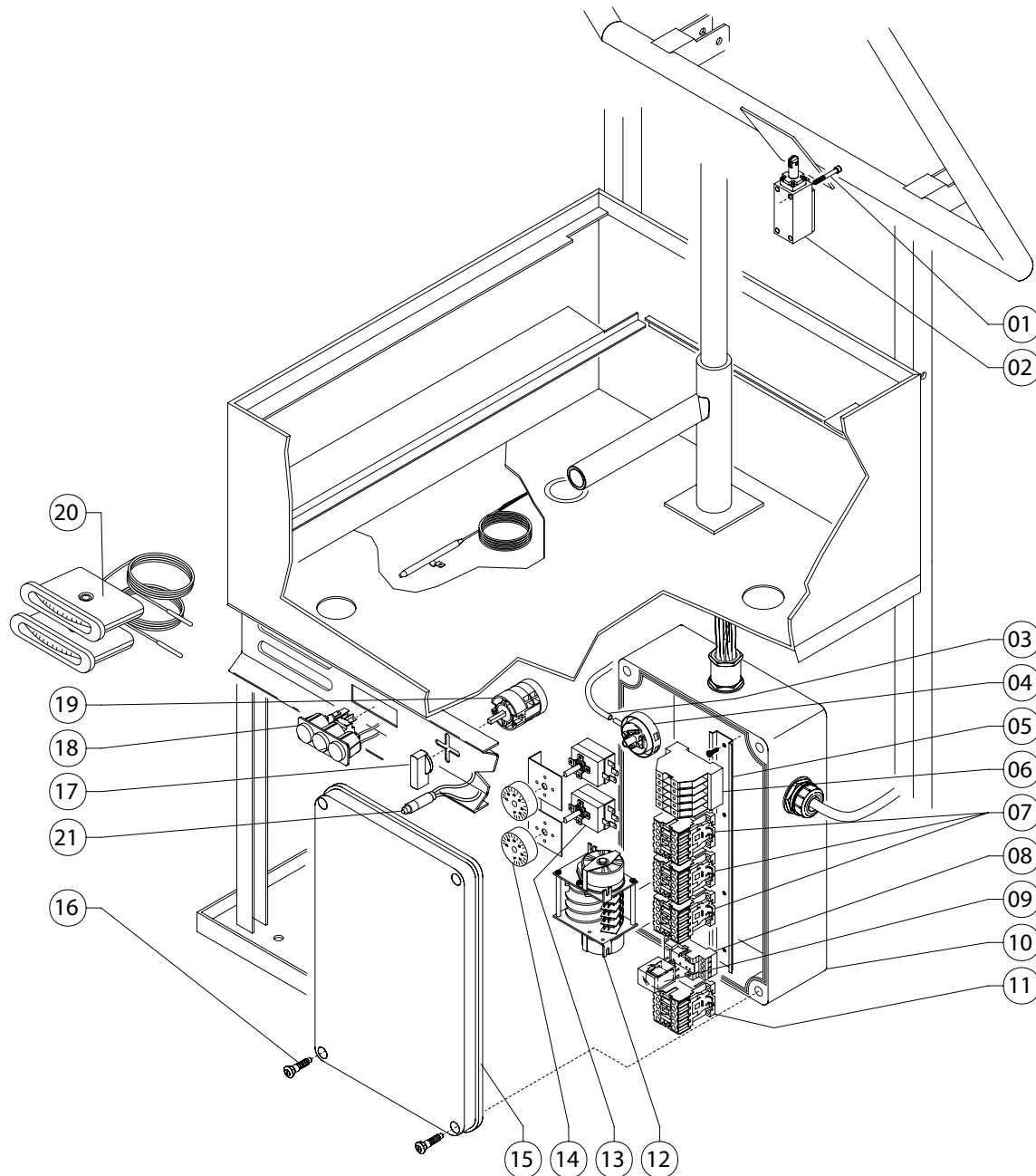

KORAL 1100 -1200-1250-1350

TAV.38

CESTELLI

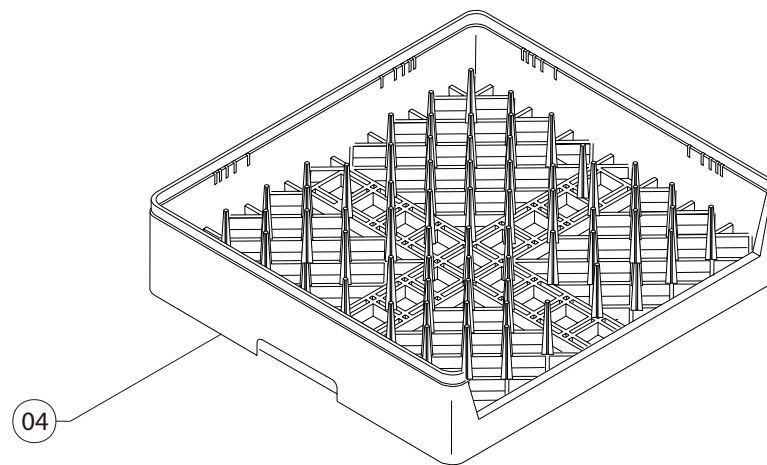
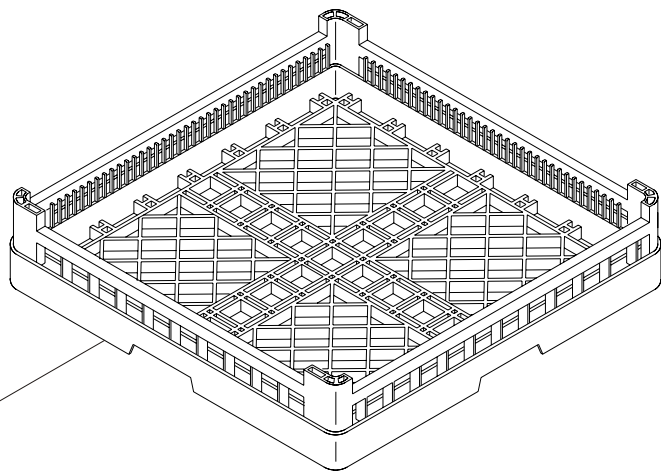
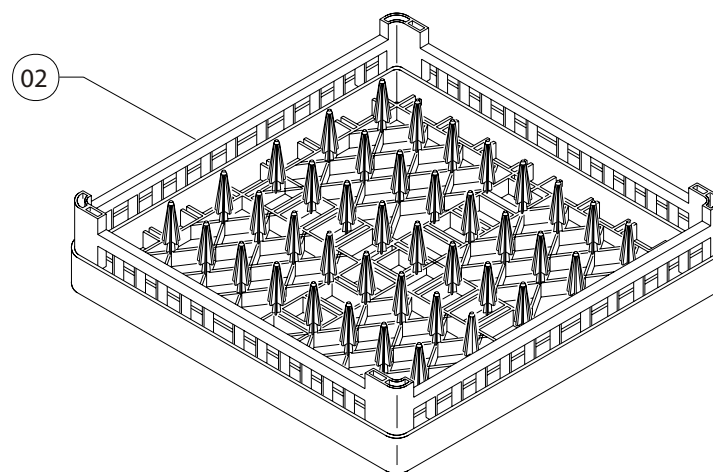
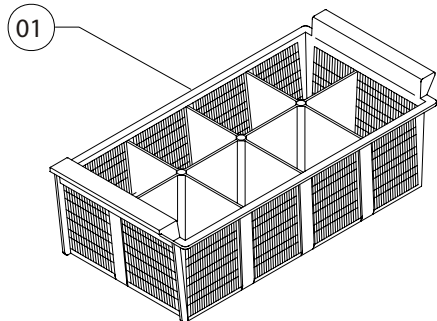

KORAL 1600-1650

TAV.39

CESTELLI

